

HIGHLINE MFG.
INC.

1999

BALE PRO 6800

**Assembly-Operator
Parts Manual**

Memo

To: All Departments
From: Shane Tulik
CC: Mario Piche
Date: 12/23/98
Re: Manitoba Highways and Transportation – Lighting and Marking

As discussed previously, legislation was passed in Manitoba requiring lighting and marking on all agricultural equipment. This legislation applies to all equipment manufactured on or after January 1, 1998 and must be adhered to for all machines sold into Manitoba. The following Highline machines are affected by this legislation:

1. 500BM Balemover
2. 700BM Balemover
3. 1400BM Balemover
4. Balepro Hitch
5. Topgun
6. **BP6800 Baleprocessor**
7. BP7800 Baleprocessor
8. XL6084 Rockpicker
9. XL78 Rockpicker.

I would like to again express the need to address this situation immediately by supplying either the dealers or the end user with the required lighting and marking in order to meet the Manitoba legislation. The details of supplying the safety kits will be shared by the sales, production, and customer service departments. These measures will supply the equipment owners with the necessary safety equipment and will allow us to retroactively meet and exceed the required legislation by following ASAE S279.10. The following light kits can be found in CMS:

Model	Light Kit Part No.	Other Requirements
500BM Balemover	40164	reflectors
700BM Balemover	40164	reflectors
1400BM Balemover	40169	reflectors
Balepro Hitch	Same requirement as BM	reflectors
Topgun	48089	reflectors
BP6800 Baleprocessor	48101	reflectors
BP7800 Baleprocessor	48103	reflectors
XL78 Rockpicker	To be completed	reflectors
XL6084 Rockpicker	To be completed	reflectors

Warranty

HIGHLINE Mfg. Inc. warrants its products to the original owner for a period of two years from date of purchase, subject to the following provisions:

- 1st year Warranty covers Parts & Labor
- 2nd year Warranty covers Parts Only
- Warranty registration must be submitted to HIGHLINE Mfg. Inc. within 30 days of purchase.
- HIGHLINE Mfg. Inc. is not liable for any damages to this equipment resulting from use of this equipment that is inconsistent with this manual and such is not covered under this warranty.
- Warranty will be void, and HIGHLINE Mfg. Inc. will not be liable in any way, if the equipment is used for any other purpose than the intended agricultural application.
- All warranty service must be handled through an authorized HIGHLINE Mfg. Inc. dealer. At the time of requesting warranty service, the purchaser must present evidence of the delivery date of the equipment. The purchaser shall pay any premium for requested overtime, any charge for making service calls, and any charges incurred in transporting the equipment to and from the location of the warranty service. Freight costs associated with warranty repairs are not reimbursable.
- Any labor subject to warranty must be authorized by a HIGHLINE Mfg. Inc. Representative, before work is started.
- Warranty will be void if any component of this equipment is altered or modified in any way, unless written permission is given by HIGHLINE Mfg. Inc.
- Equipment used for rental, custom work, industrial or construction use will not be warranted by HIGHLINE Mfg. Inc.
- HIGHLINE Mfg. Inc. will not assume any responsibility for any damage occurring to equipment which this equipment may be attached.
- Warranty terms and conditions are subject to provincial and state legislation.
- Warranty is limited to the Purchase price paid for the equipment , up to the Manufacturers suggested retail price. ***ANY LIABILITY RESULTING FROM THE WORKMANSHIP OF THIS EQUIPMENT*** is limited to the purchased price paid. HIGHLINE Mfg. Inc. assumes no responsibility whatsoever for liability resulting from the misuse or improper operation and maintenance of this equipment.

NOTES:

Highline Mfg. Inc. claims proprietary rights to the material disclosed herein. This drawing is issued for engineering information only. It may not be reproduced nor the information herein be used for any purpose without written permission from Highline Mfg. Inc.
The equipment shown is protected by patents.

- Default Tolerances:**
- LINEAR DIMS: $\pm .005$
 - ANGLES: $\pm .125$
 - CONCENTRICITY: $\pm .010$
 - ROUNDED CORNERS: $R = .010$
 - WALL THICKNESS: $\pm .005$
 - DRILL DIA: $\pm .005$
 - THREADS: $\pm .005$
 - GEOMETRIC: $\pm .010$
- DIMS ARE IN INCHES
-

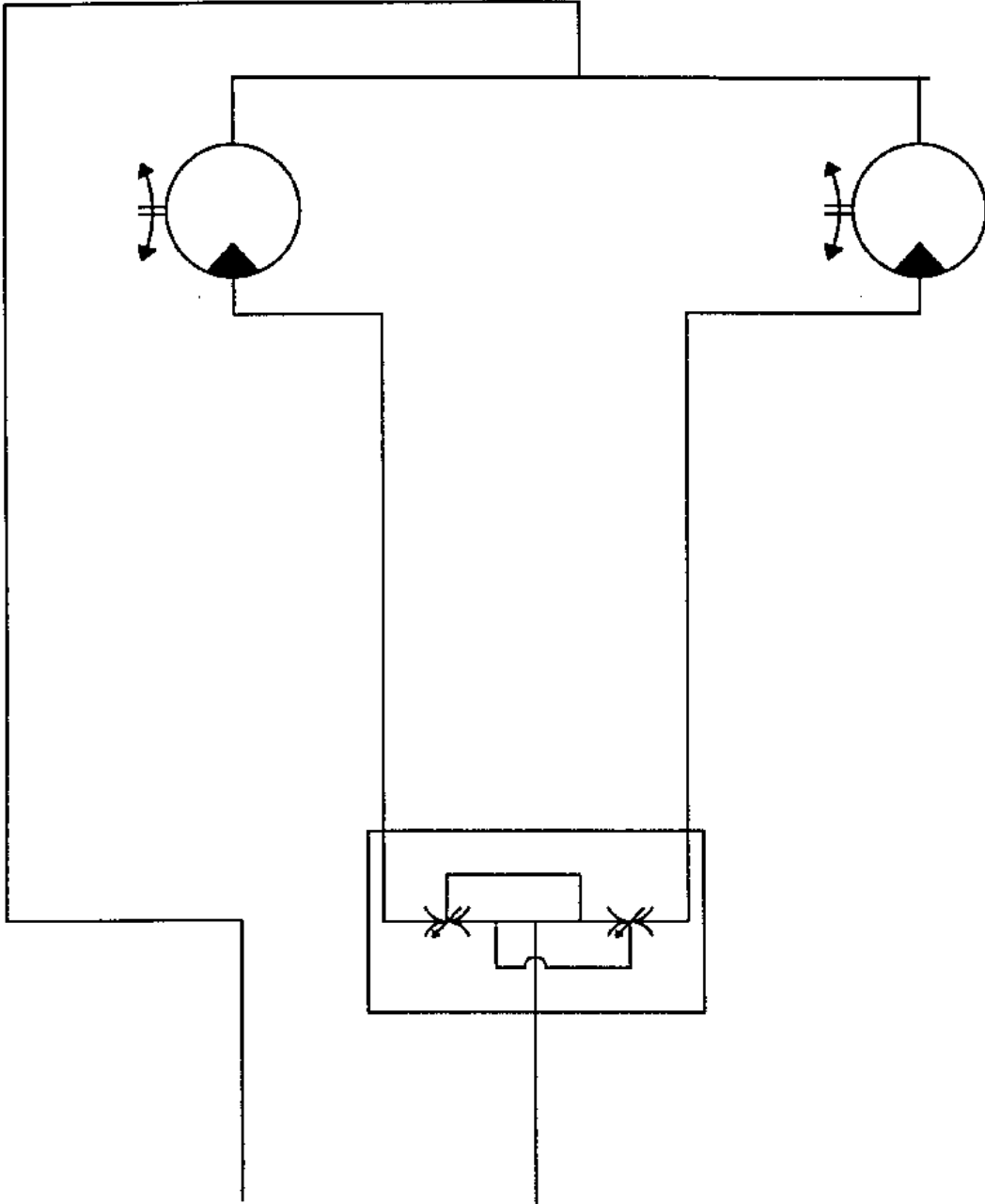

REVISIONS

REV	DESCRIPTION	DATE	CHANGED BY
A	INITIAL RELEASE	15 JAN 99	BJW
B			
C			
D			
E			
F			

Date:

Engineering: SJT	15 JAN 99
Drawn By: BJW	
Page: 1 of 1	
Scale: NTS	
Size: A	
Sheet: MATL	

Module: BP

Description:

HYDRAULIC MOTOR SCHEMATIC

MFG INC. 49024
HIGHLINE
 Part: A

NOTES:

Highline Mfg. Inc. claims proprietary rights to the material disclosed herein. This drawing is issued for engineering information only. It may not be reproduced nor the information herein be used for any purpose without written permission from Highline Mfg. Inc.

The equipment shown is protected by patents.

Default Tolerances:

1. LINEAR DIMS. $\pm .005$ FRACTIONAL $\pm .0125$
2. ANGLES $\pm .1/2^\circ$
3. CONCENTRICITY AND THE POSITIONAL TOLERANCES BOTH $\pm .005$
4. SURFACE FINISH $125 \mu\text{in. RMS}$
5. MACHINE INTERNAL TOLERANCES $\pm .005$
6. BREAK SLOPE CORNER

UNITS ARE IN INCHES

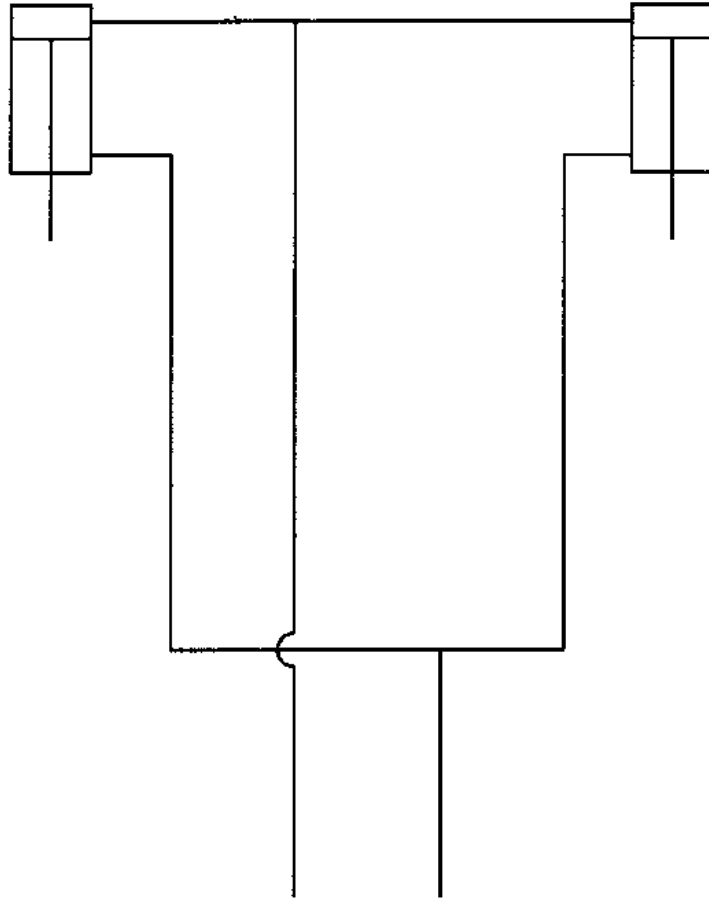

REVISIONS

LTR	DESCRIPTION	DATE	CHANGED BY
A	INITIAL RELEASE	15 JAN 99	BJW
B			
C			
D			
E			
F			

Date:

Engineering: SJT	15 JAN 99
Drawn By: BJW	
Scale: A	
Sheet: 1 of 1	
MATL	

Model: BP6800

Description:	HYDRAULIC CYLINDER ASSEMBLY
Draw No:	

Table of Contents

1. Table of Contents.....	1
2. President's Message.....	2
3. Safety Precautions.....	3
4. Operating Instructions.....	3
5. Maintenance.....	6
6. Assembly & Installations.....	9
Flail Drum Assembly.....	9
Flail Drum Installation.....	10
Feed Roller Assembly.....	11
Feed Roller Installation.....	12
Discharge Deflector Installation.....	14
Screen and Bale Deflector Installation.....	16
CV Installation.....	17
Flail Guard Rod Installation.....	18
Hub Assembly.....	20
Wheel Assembly.....	21
Cart Assembly.....	22
Tub on Cart Installation.....	24
Cylinder Assembly.....	26
Hydraulic Layout.....	28
CV Assembly.....	30
7. Specifications.....	32

2. President's Message

Congratulations on your purchase of the Bale Pro 6800! Bale Pro, a proven name in livestock feed handling equipment, is manufactured by Highline Mfg. Inc. A company with a manufacturing team that has over 25 years experience in the farm implement industry.

This operator's manual has been prepared to provide information necessary for safe and efficient operation of your *Bale Pro 6800*. In the manual you will find safety procedures, maintenance routines and detailed parts diagrams.

The *Bale Pro 6800* was designed for controlled, more aggressive processing with less bunching. A little time and effort spent in proper maintenance will increase the performance and durability of your bale processor.

In order to maintain high standards, improvements are made from time to time. Highline Mfg. Inc. reserves the right to make those changes and improvements when practical to do so without incurring any obligation to make such changes and improvements on machines sold previously.

Should the need arise, this manual will assist you in acquiring replacement parts. Should your dealer not have the parts you require in stock, the dealer will be happy to order them for you. Also if you should find that you require information not covered in this manual, feel free to consult your local dealer or Highline.

Highline Mfg. Inc. thanks and congratulates you for selecting a *Bale Pro 6800* as the machine of your choice.

Sincerely,

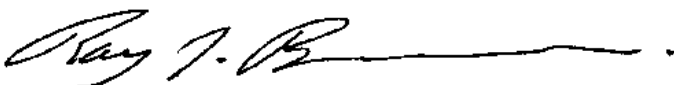

Raymond J. Bussière, President

PO Box 307, Vonda, Saskatchewan, S0K 4N0

Phone 1-800-665-2010 Fax (306) 258-2010

Internet Address: <http://www.spectramedia.com/highline/>

3. Safety Precautions

WORK SAFELY - FOLLOW THESE RULES

CAREFUL OPERATION IS THE BEST INSURANCE AGAINST AN ACCIDENT

- Keep children and adults away from discharge area while processing.
- Know the controls and what they do.
- Check machine to ensure nothing restricts moving or rotating parts.
- Ensure PTO is disengaged before starting tractor.
- Never leave tractor while PTO is engaged.
- Lower forks to ground after operation.
- Never attempt to manually remove debris while PTO is activated.
- Do not transport Bale Pro on highway with CV extension shaft on machine or with bales in tub or on the forks
- Disconnect CV before unplugging or adjusting processor.
- Always keep safety shields in place.
- Relieve pressure in hydraulic lines before disconnecting lines or performing other work on the hydraulic system.
- Never allow anyone to stand behind processor while loading bales.

 ***Before operating the Bale Pro 6800, be sure to review all the instructions and familiarize yourself with the processor's features.***

4. Operating Instructions

Successful operation of the Bale Pro 6800 is dependent upon the quality of the bale, height of the feed rollers and flail guard and also on the operator. The following steps ensure proper operation. Please read carefully before operating your Bale Pro 6800.

1. Ensure that drawbar on tractor is extended such that the pin is 17 inches from the groove on the PTO on tractor.
2. It is recommended that hitch tongue is placed in the second hole from the top of the BP6800 hitch frame. This will ensure proper drawbar location and extend the life of the CV.
3. Ensure that the machine is properly greased at all locations (see pages 6 and 7).
4. Position the discharge deflector by means of the Adjusting handle in the upper position for bedding, and in the lower position for windrow feeding (figure 1).
5. Adjust the flail guard rods by the raising or lowering the adjusting handle (figure 1). With the handle at its highest position, the Bale Pro will process very aggressively. Lowering the handle will decrease the aggressiveness of the processor.

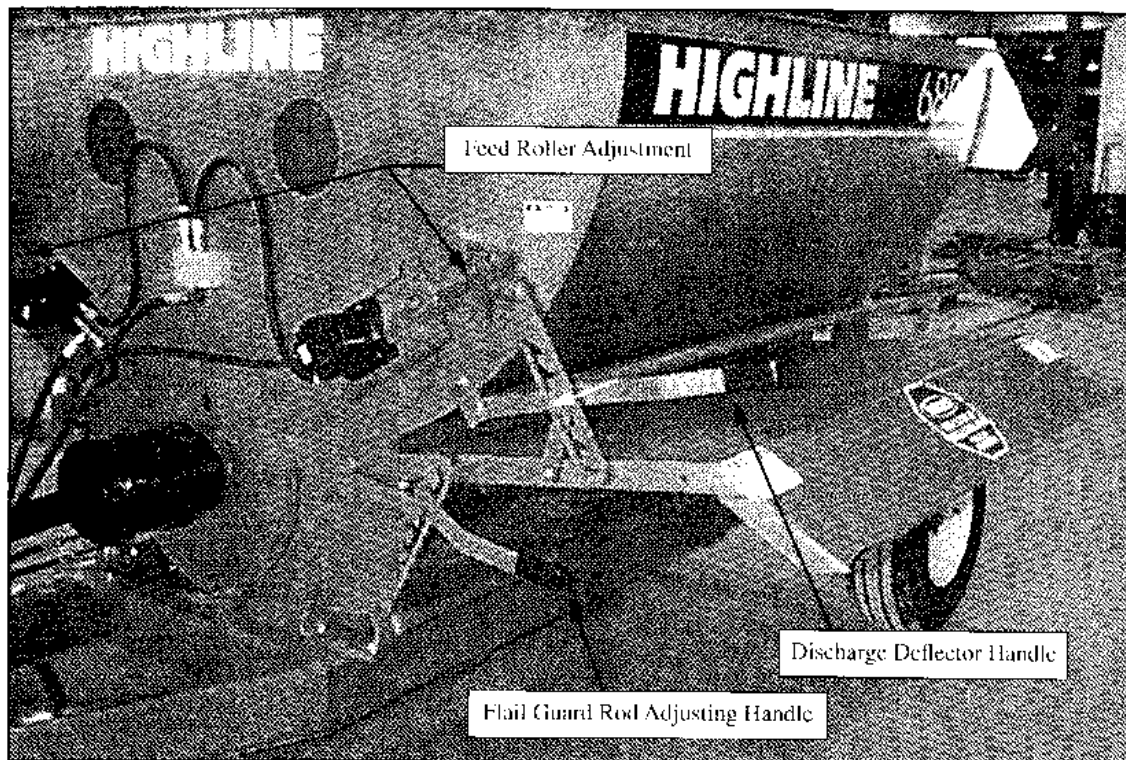

Figure 1 Manual Controls

NOTE: If the processor is too aggressive, the flails will slap back on the flail drum. Continued “backslap” can cause damage to the flail drum, flails and flail bushings. Therefore, avoid excessive “backslap” whenever possible by adjusting the flail guard rods.

6. Adjust the feed rollers with the feed roller adjusting rods to accommodate the bale size. Generally the feed rollers should be raised for larger bales and lowered for smaller bales. Major adjustments may effect the aggressiveness of the processor.
7. Before loading bale, engage PTO to ensure that the flail drum if it is operating properly. Start feed rollers using the hydraulic controls and check if the feed rollers turn in both directions. If your tractor has hydraulic flow control, alter flow so the feed rollers rotate at an adequate speed for the condition of your bales.
8. To load, lower forks **completely** and back up to bale **slowly**. Raise forks until bale falls into the processor. Another bale may be loaded onto the forks while a bale is in the processor. If a bale is loaded on the forks while one is shredded, raise the forks as high as possible, making sure that the bale on the forks does not interfere with the bale in the tub. This will reduce pressure on the hydraulic cylinder lift assembly. Orientation of the bale during loading causes the hay/straw to discharge from the processor differently. If the bale is shredded in the same direction as it was baled, the hay/straw will generally come off in layers. If the bale is shredded in the opposite way, feeding may be uneven.

- **Do not dislodge frozen bales with forks, otherwise damage to the lift mechanism may result**
9. When ready, engage tractor PTO at idle. Increase PTO speed until it reaches 1000 RPM. Make sure that before PTO is engaged, the forks are not interfering with the bale in the tub. To process, rotate the bale by means of the feed rollers. If the bale stops rotating, reverse the direction of the feed rollers.
 10. Before stopping CV, idle tractor down to reduce flail "back slap".



WARNING: Warranty will be void if any component of this machine is altered or modified in any way, unless written permission is given by Highline Mfg. Inc.

5. Maintenance

Please follow these maintenance steps, to ensure trouble free operation of your Bale Pro 6800

A. General Maintenance

- Twine must be removed from the flail drum **at least** every 25 bales. Premature bearing failure may occur if the twine is allowed to build up on the drum.
- Flail bolts should be tightened after the first ten bales then rechecked after approximately 200 bales
- Pipe Clamps (page 22) should be checked every 50 bales, and tightened if necessary

B. Lubrication

Maintaining proper lubrication of the Bale Pro 6800 is crucial for trouble free operation. Figures 4 and 5 points which require regular greasing. Below is a list of the lubrication points and the frequency of greasing of these points.

- | | |
|---|---|
| <p>1. Ball Shear Assembly
Grease every 8 hours.</p> <p>2. Cross and Bearing
Grease every 8 hours.</p> <p>3. Telescopic Members
Grease every 8 hours.</p> <p>4. Ball and Socket
Grease every 8 hours.</p> <p>5. Center Housing
Grease every 24 hours.</p> | <p>6. Flail Drum Bearing (Front and Rear)
Grease every fifty bales</p> <p>7. Feed Rollers (Left and Right)
Grease every one hundred bales.</p> <p>8. Pipe Clamps (Left and Right)
Grease every one hundred bales.</p> <p>9. Wheel Hub (Left and Right)
Grease every one hundred bales.</p> <p>10. Forks (Left and Right)
Grease every one hundred bales.</p> |
|---|---|

Note: When CV is under constant angle applications, there must be a lube interval of 4 hours for 1 through 5

Use low-temperature grease when the temperature reaches below 0 degrees Celsius (32 degrees Fahrenheit)

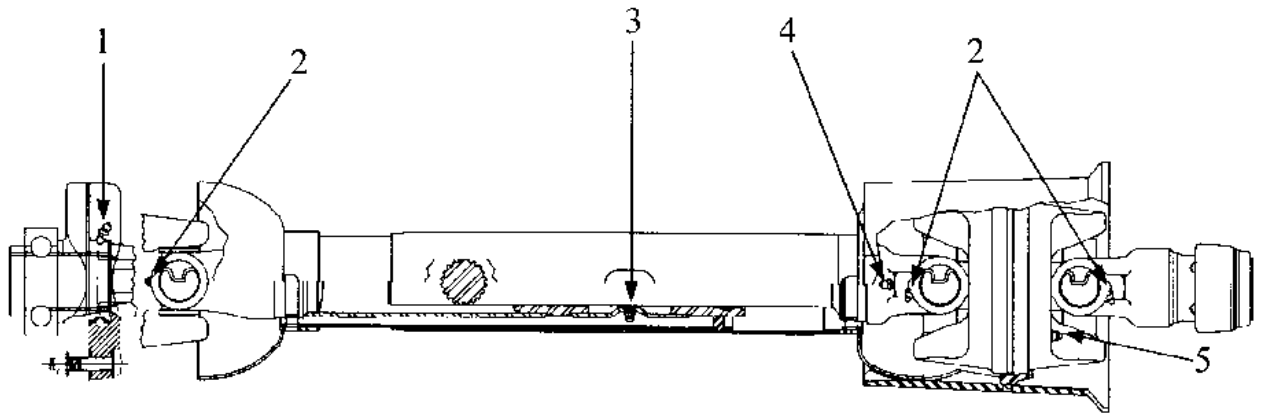

Figure 4 CV Lubrication

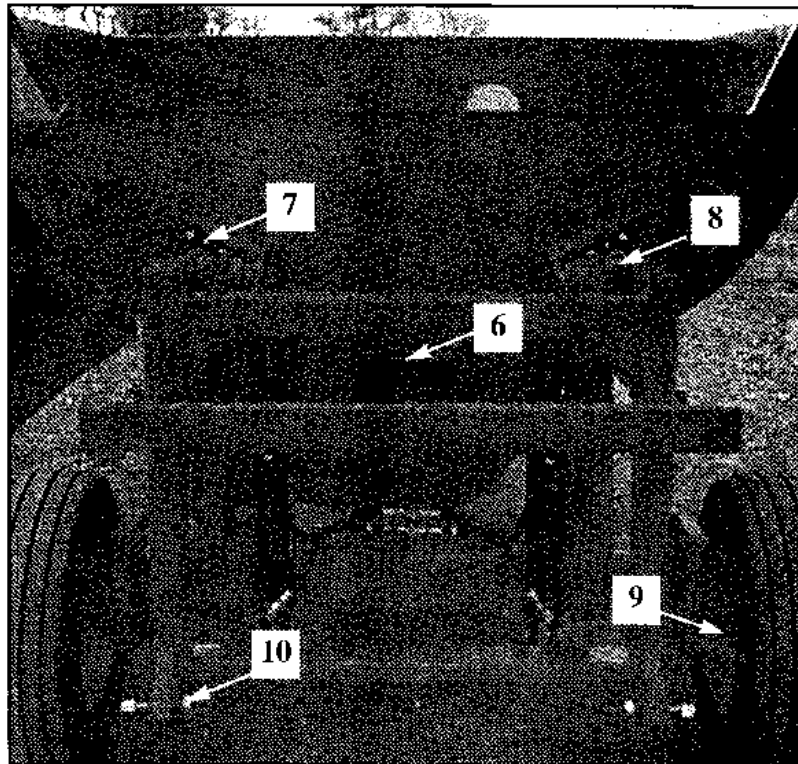
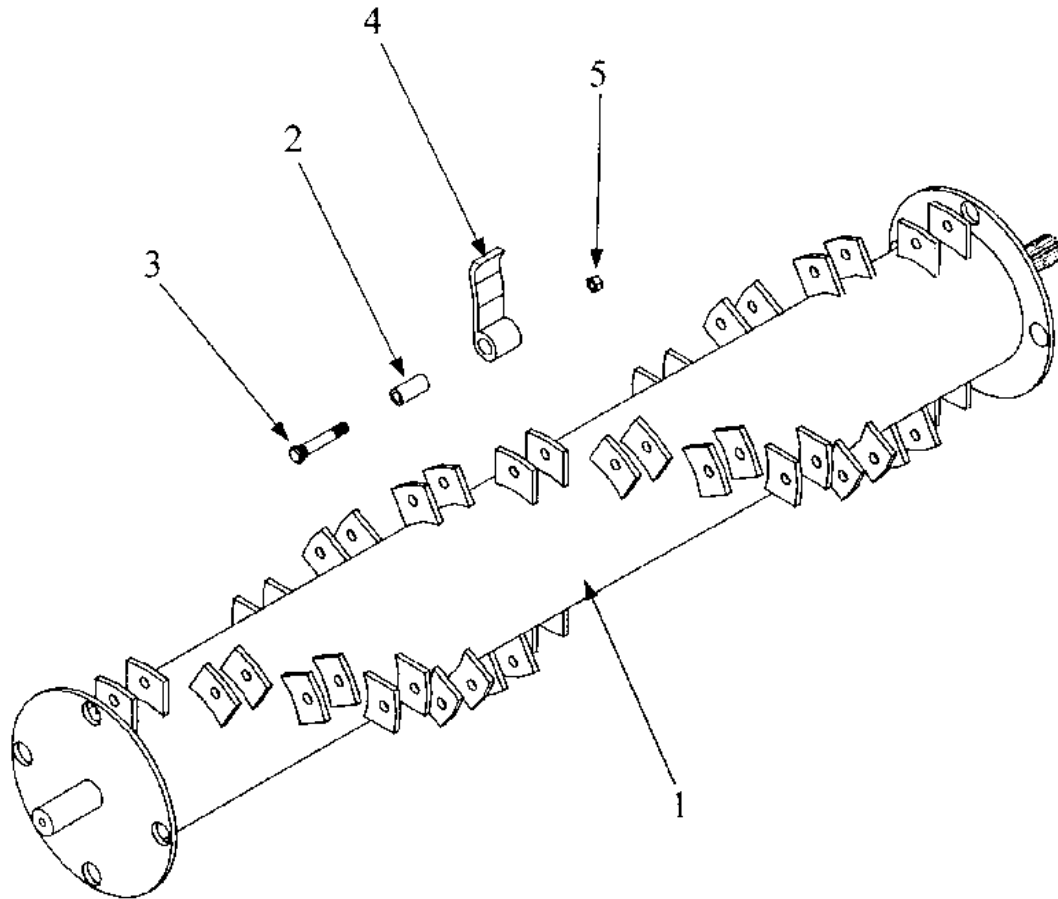

Figure 5 Assorted Lubrication Points

6. Assembly & Installations

Flail Drum Assembly



Item No.	Part No.	Description
1	49009	Flail Drum (no flails)
2	E2083	Flail Bushing
3	45095	5/8" x 3-3/4" UNF Gr. 8 Stud
4	E3694	Flail E3694
5	SLNF10	5/8" UNF Lock Nut
	49008	Flail Drum Complete (flails installed)

175044

31170

Flail Drum Installation

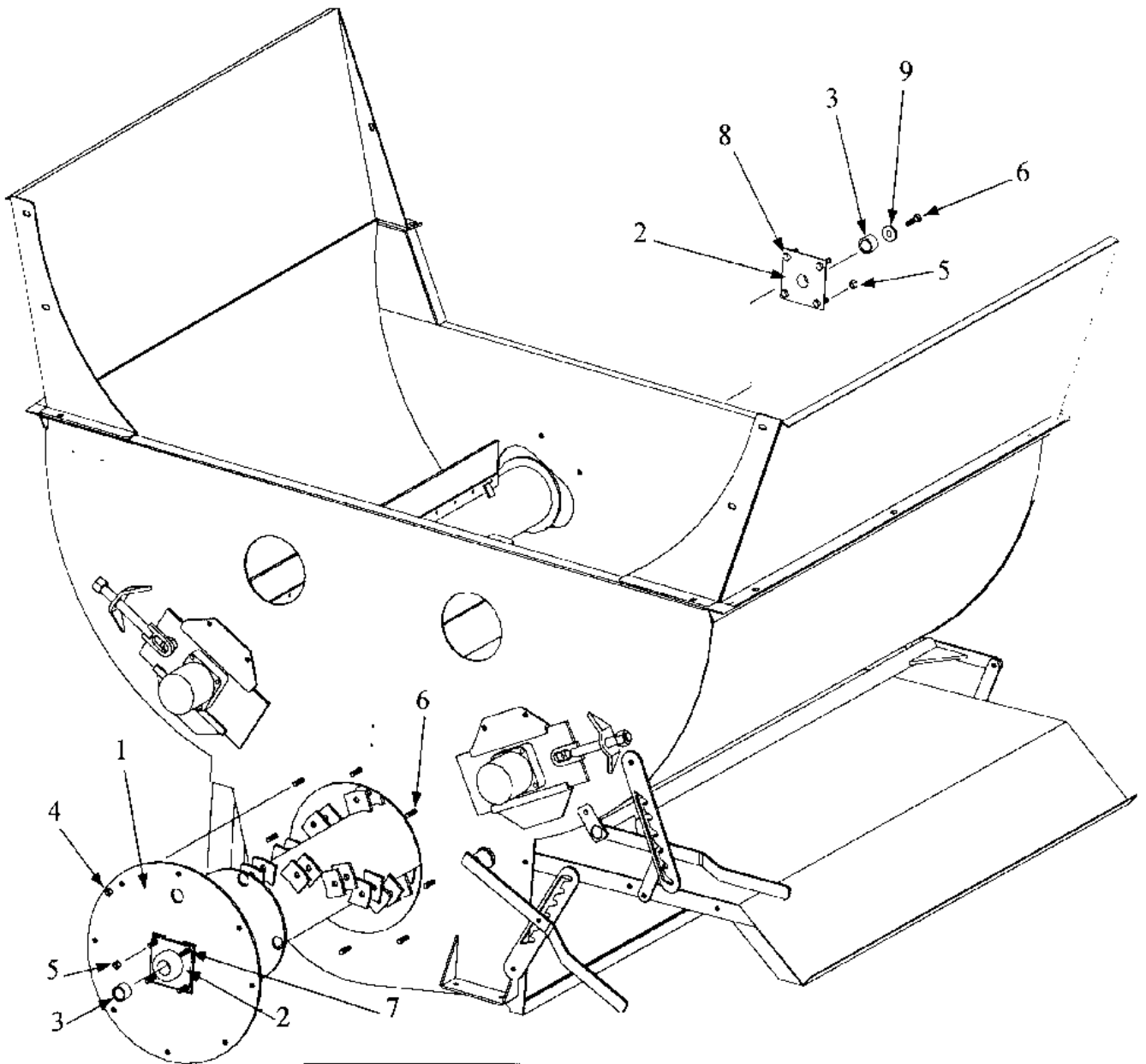

Item No.	Part No.	Description
1	49013	Front Bearing Plate
2	92091	1-3/4" Flange Bearing
3	E3646	Spacer Bushing
4	LNC08	1/2" Lock Nut
5	LNC10	5/8" Lock Nut
6	B5C0824P	1/2" x 1-1/2" UNC Gr. 5 Bolt
7	C5C1048P	5/8" x 3" UNC Gr. 5 Carr. Bolt
8	C5C1040P	5/8" x 2-1/2" UNC Gr. 5 Bolt
9	92081	2" x 9/16" x 3/16" Washer

Feed Roller Assembly

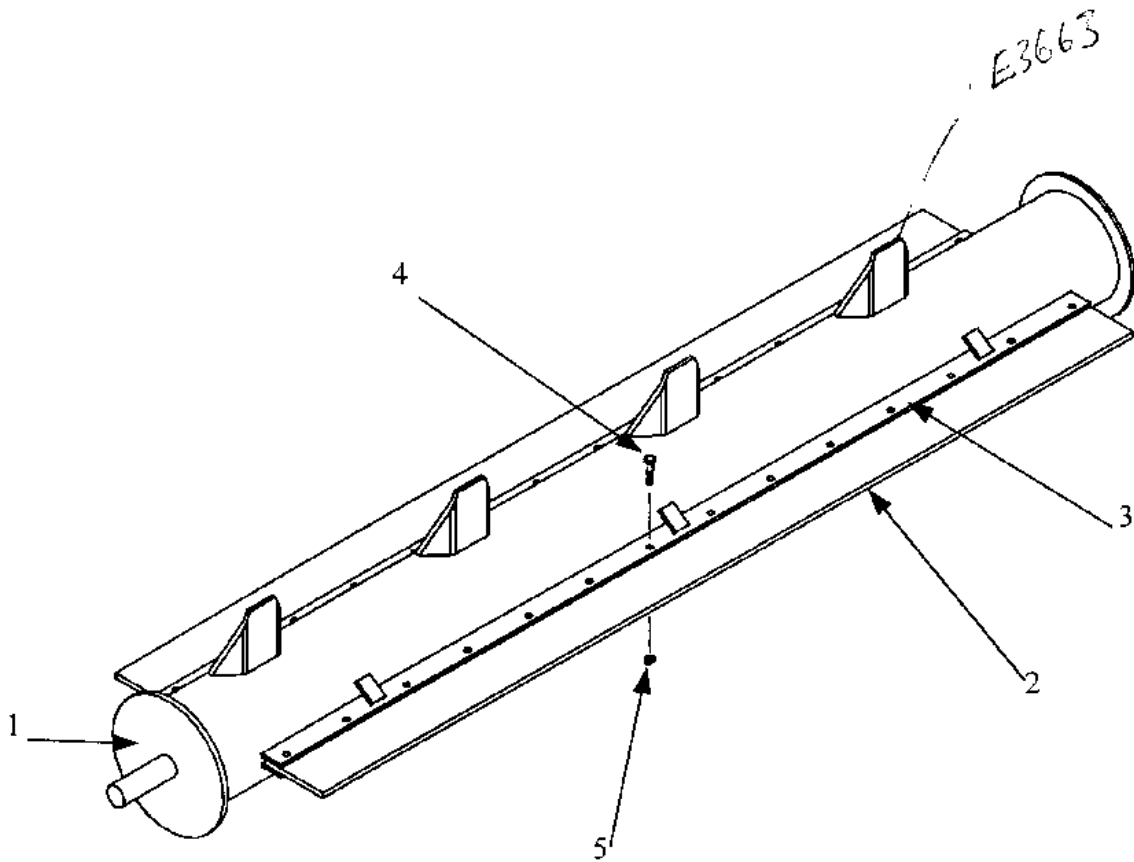

Item No.	Part No.	Description
1	49017	Feed Roller Complete
2	E3581	3/8" x 4-1/2" x 62" Belting
3	E3582	3/8" x 1-1/2" x 62" Back Plate
4	B5C0528P	5/16" x 1 3/4" UNC Gr. 5 Bolt
5	LNC05	5/16" UNC Lock Nut

6 49017 FEED ROLLER NO BELTING

Feed Roller Installation

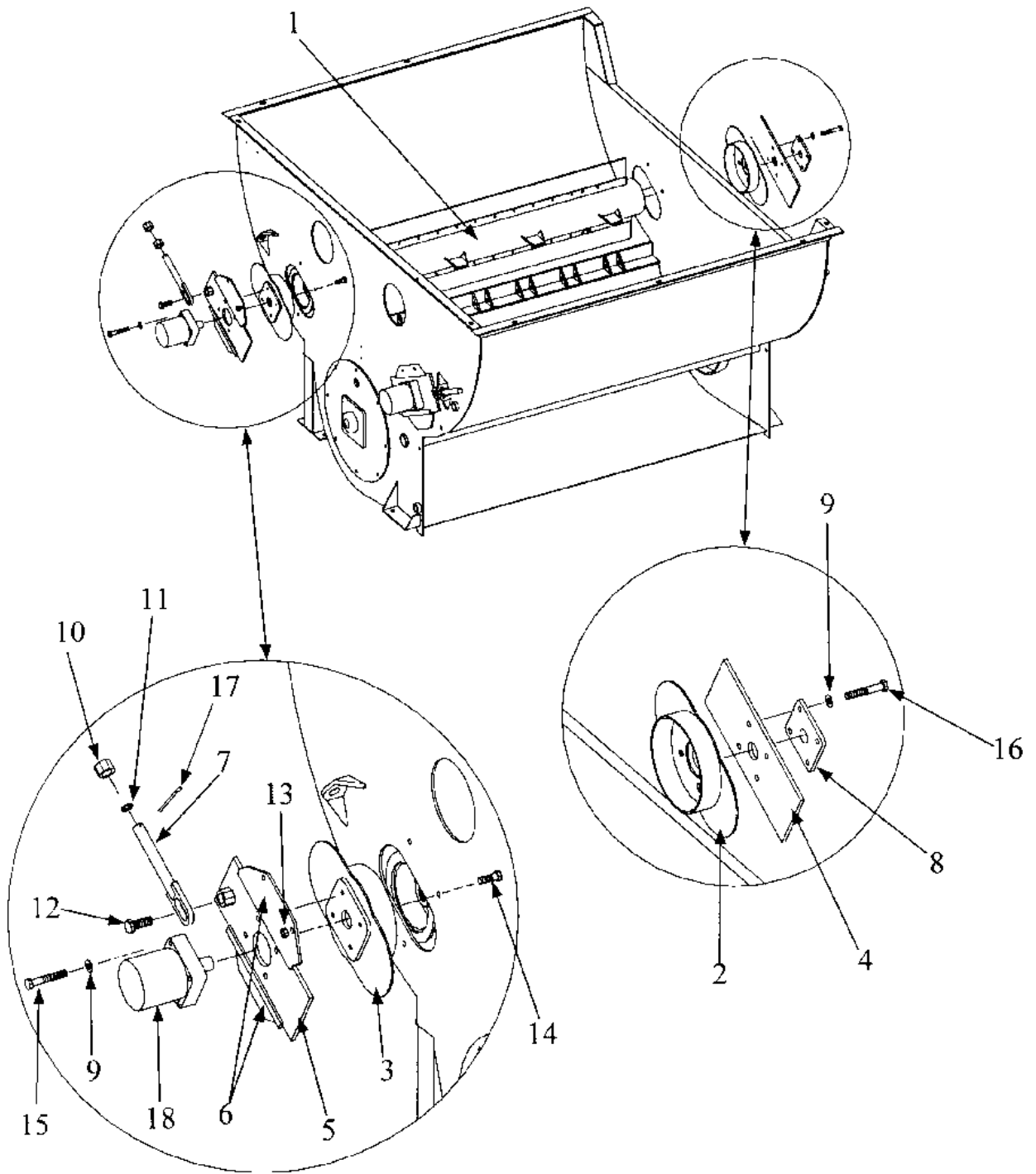

Item No.	Part No.	Description
1	49017	Feed Roller (complete)
2	47012	Rear Twine Guard
3	47019	Front Twine Guard
4	49015	Rear Slide Plate
5	49016	Front Slide Plate
6	E3227	Slide Plate Retainer
7	45127	Feed Roller Adjusting Rod
8	92094	1-3/8" Flange Bearing
9	LW08P	1/2" Lock Washer
10	NRAHCME16	1" ACME Right Hand Nut
11	LW16P	1" Lock Washer
12	B5C1624P	1" x 1-1/2" UNC Gr. 5 Bolt
13	LNC08	1/2" Lock Nut
14	B5C0824P	1/2" x 1-1/2" UNC Gr. 5 Bolt
15	BS5C084P	1/2" x 2-1/2" Socket Head Cap Screw
16	B5C0828P	1/2" x 1-3/4" UNC Gr. 5 Bolt
17	CP0332	3/16" x 2" Cotter Pin
18	92145	Hydraulic Motor RE 32090 500

32647

Asst Kit

Discharge Deflector Installation

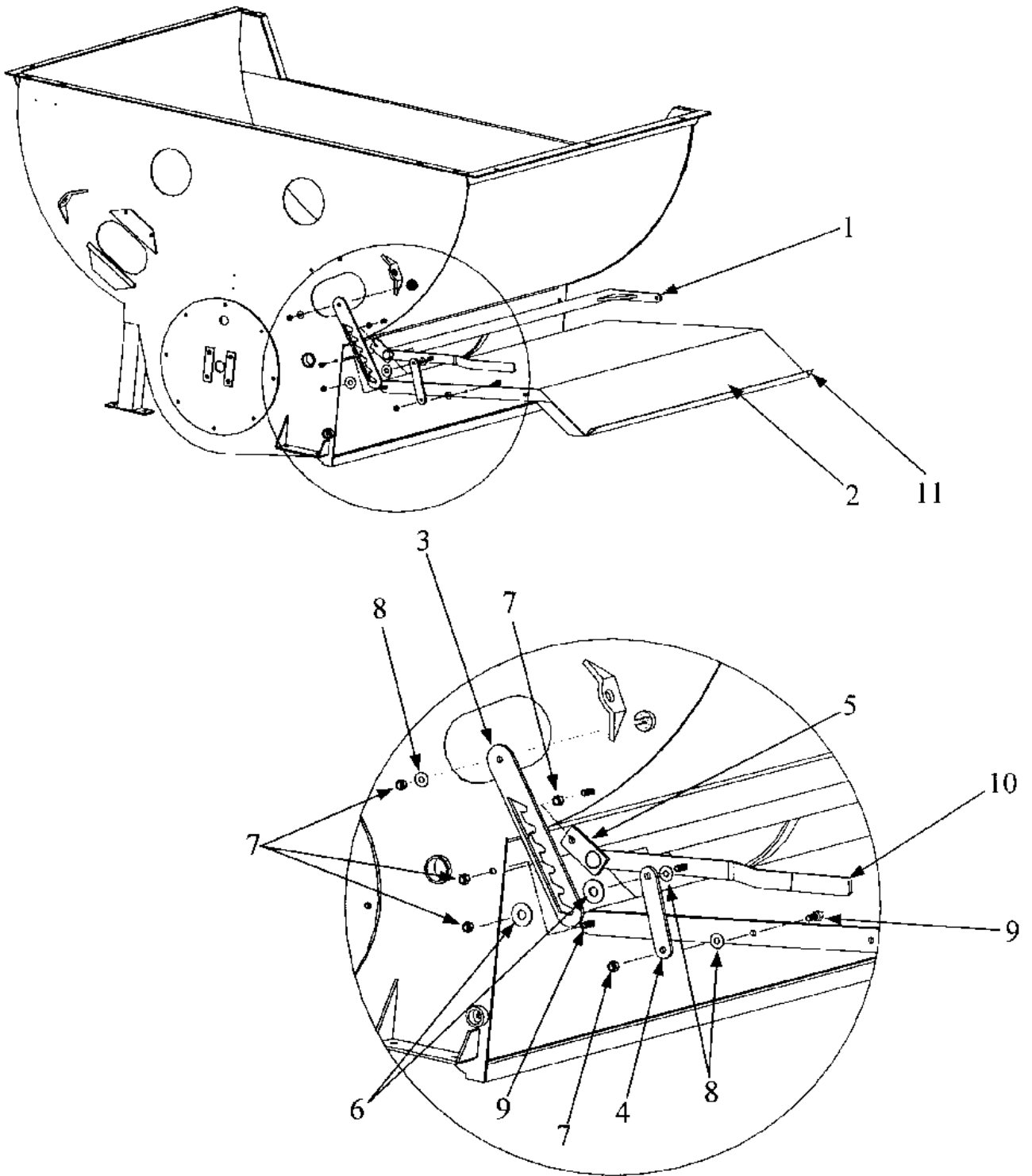

Item No.	Part No.	Description
1	45196	Discharge Lever
2	47003	Discharge Deflector
3	E2093	Adjusting Bar
4	E2935	Connecting Link
5	45197	Discharge Pivot Assembly
6	92081	2" x 9/16" x 3/16" Washer
7	LNC08	1/2" Lock Nut
8	FW08P	1/2" Flat Washer
9	B5C0824P	1/2" x 1-1/2" UNC Gr. 5 Bolt
10	92127	Rubber Handle Grip
11	92223	Rubber Cap Protector

Screen and Bale Deflector Installation

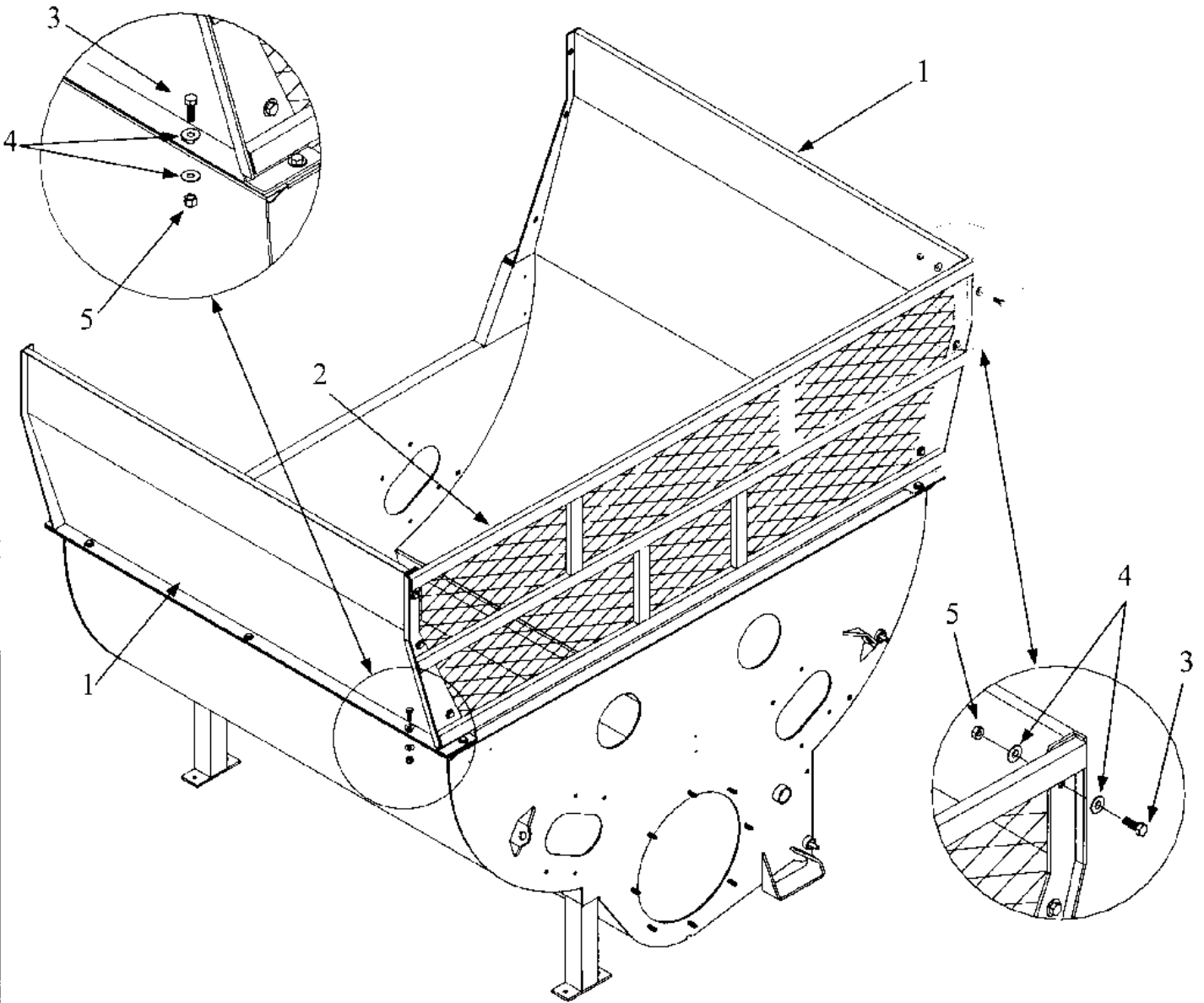

Item No.	Part No.	Description
1	49014	Bale Deflector
2	49007	Spill Screen
3	B5C0824P	1/2" x 1-1/2" UNC Gr. 5 Bolt
4	FW08P	1/2" Flat Washer
5	LNC08	1/2" Lock Nut

CV Installation

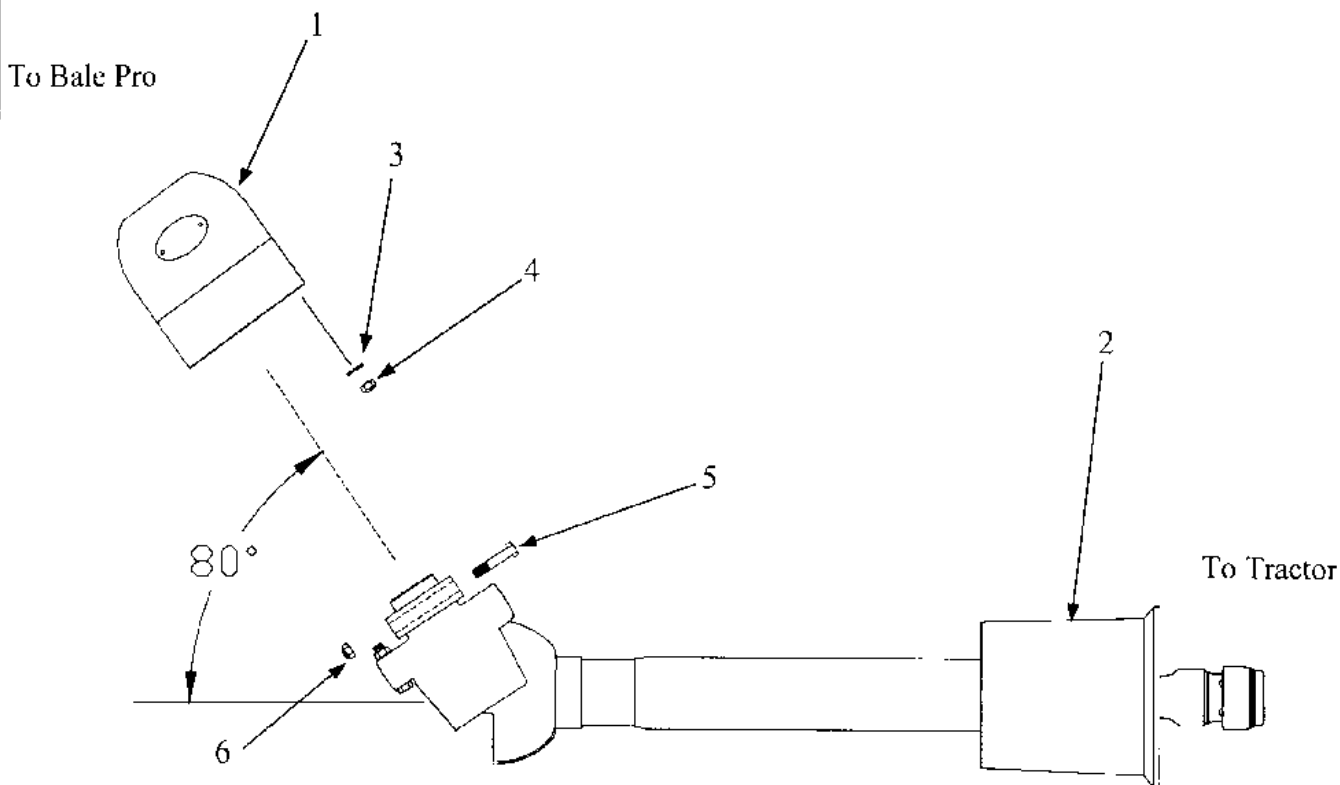

⚠ NOTE: EXCEEDING AN 80 DEGREE ANGLE BETWEEN BALE PROCESSOR AND TRACTOR WILL VOID CV WARRANTY

CV NOT TO BE USED ON THE FRONT OF BI-DIRECTIONAL TRACTOR, OTHERWISE WARRANTY WILL BE VOID

Item No.	Part No.	Description
1	30284	CV Shield
2	45230	CV
3	FW10P	5/8" Flat Washer
4	JLNC10	5/8" Locking Jam Nut
5	B5C1056P	5/8" x 3-1/2" UNC Gr. 5 Bolt
6	LNC10P	5/8" Lock Nut

Flail Guard Rod Installation

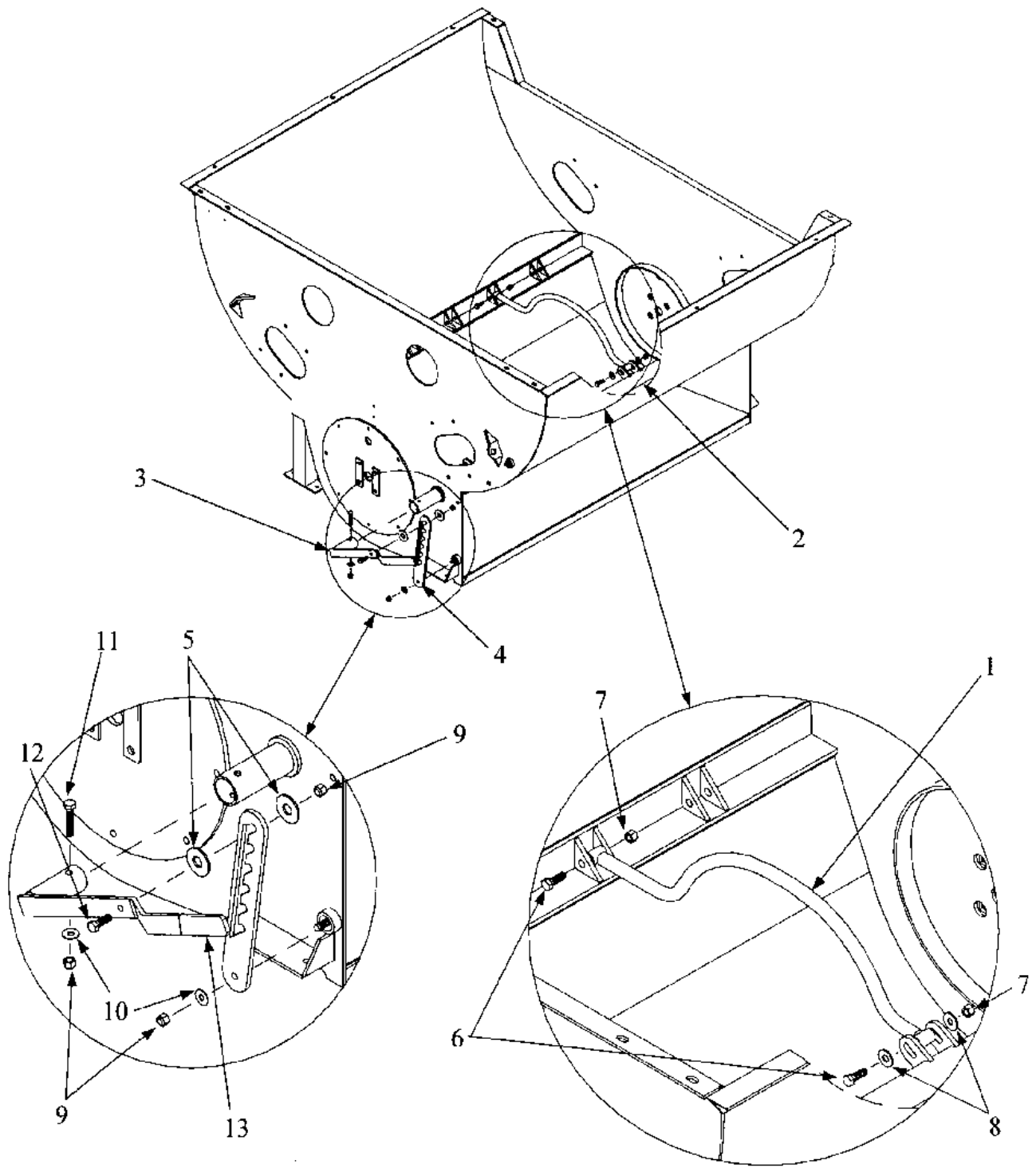

Item No.	Part No.	Description
1	49011	Flail Guard Rod
2	49010	Flail Guard Rod Adjusting Bar
3	47006	Flail Guard Adjusting Handle
4	E3695	Adjusting Bar
5	92081	2" x 9/16" x 3/16" Washer
6	B5C0956P	9/16" x 3/1/2" UNC Gr. 5 Bolt
7	LNC09P	9/16" Lock Nut
8	FW09P	9/16 Flat Washer
9	LNC08P	1/2" Lock Nut
10	FW08P	1/2" Flat Washer
11	B5C0856P	1/2" x 3-1/2" UNC Gr. 5 Bolt
12	B5C0840P	1/2" x 2-1/2" UNC Gr. 5 Bolt
13	92127	Rubber Handle Grip

Hub Assembly

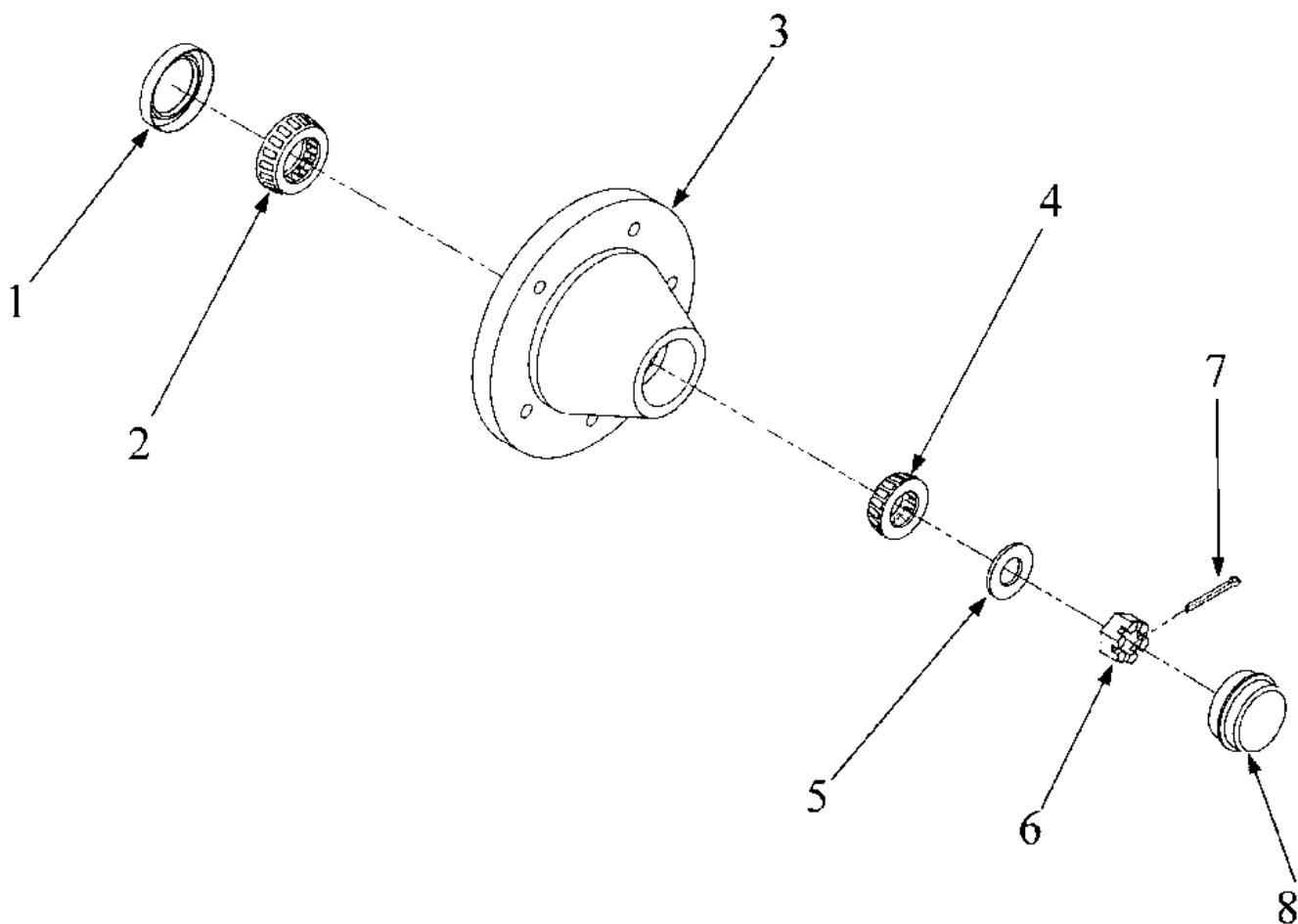

Item No.	Part No.	Description
1	30346	Oil Seal
2	30345	Bearing, 1-1/4" Bore
3	30373	Hub
4	30344	Bearing, 1-1/2" Bore
5	30371	Washer
6	30372	Castellated Nut
7	CP0332	3/16" x 2" Cotter Pin
8	30342	Dust Cap
	45224	HA611-9 Hub Complete

Wheel Assembly

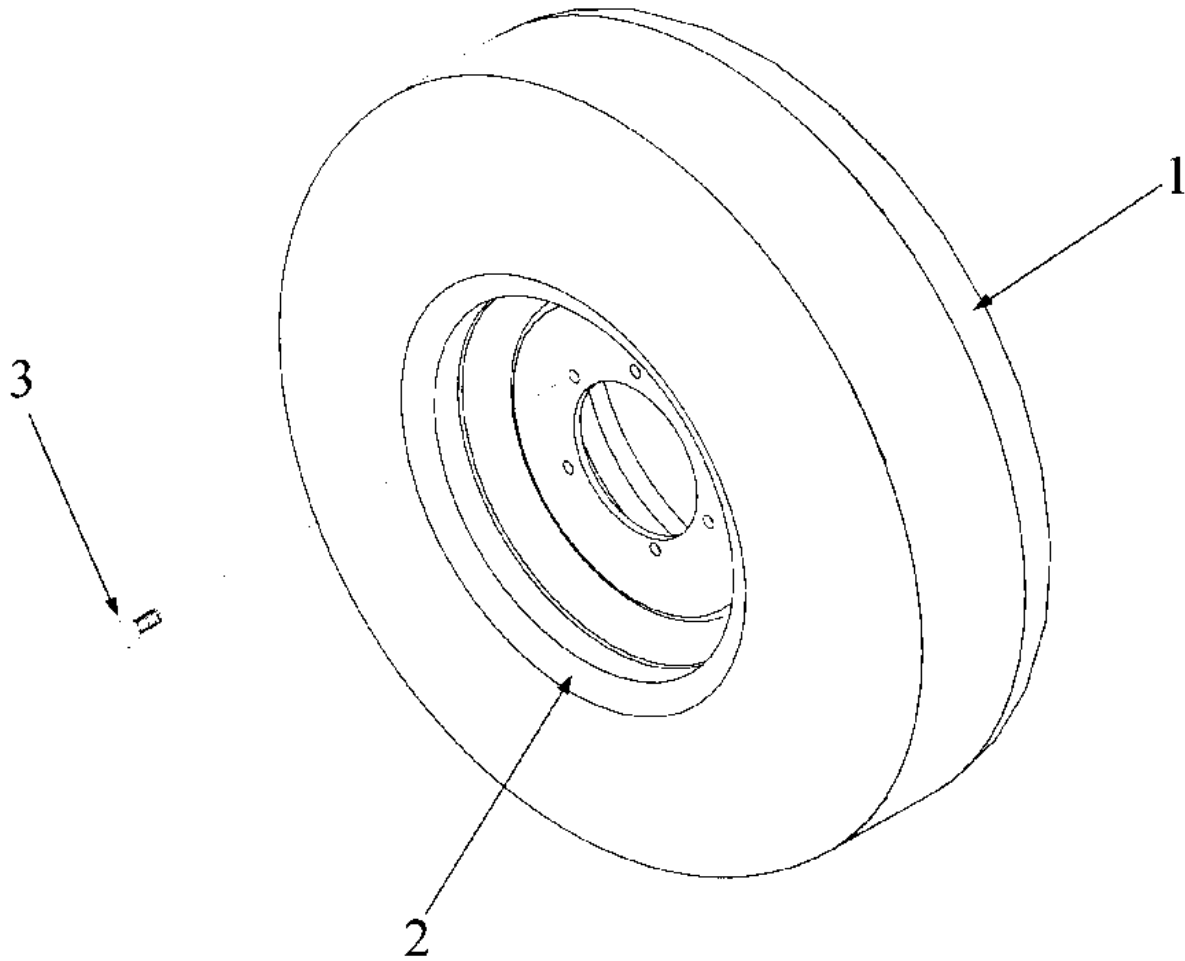

Item No.	Part No.	Description
1	45222	11L - 15FI Highway Service Tire
2	45223	15 x 8 Rim
3	30347	1/2" Wheel Bolt
Not Shown	91048	Valve Stem

Cart Assembly

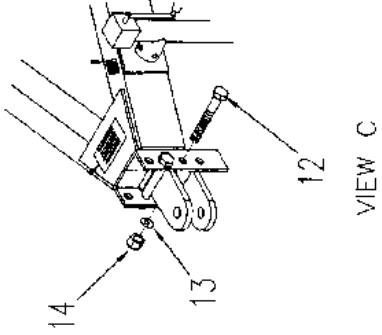
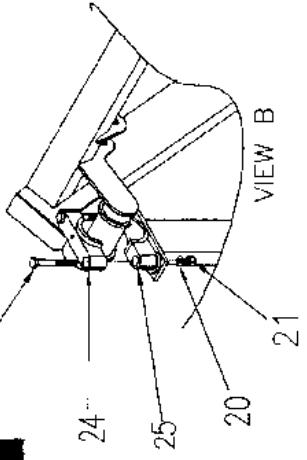
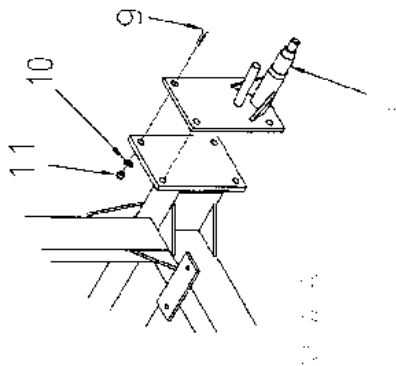
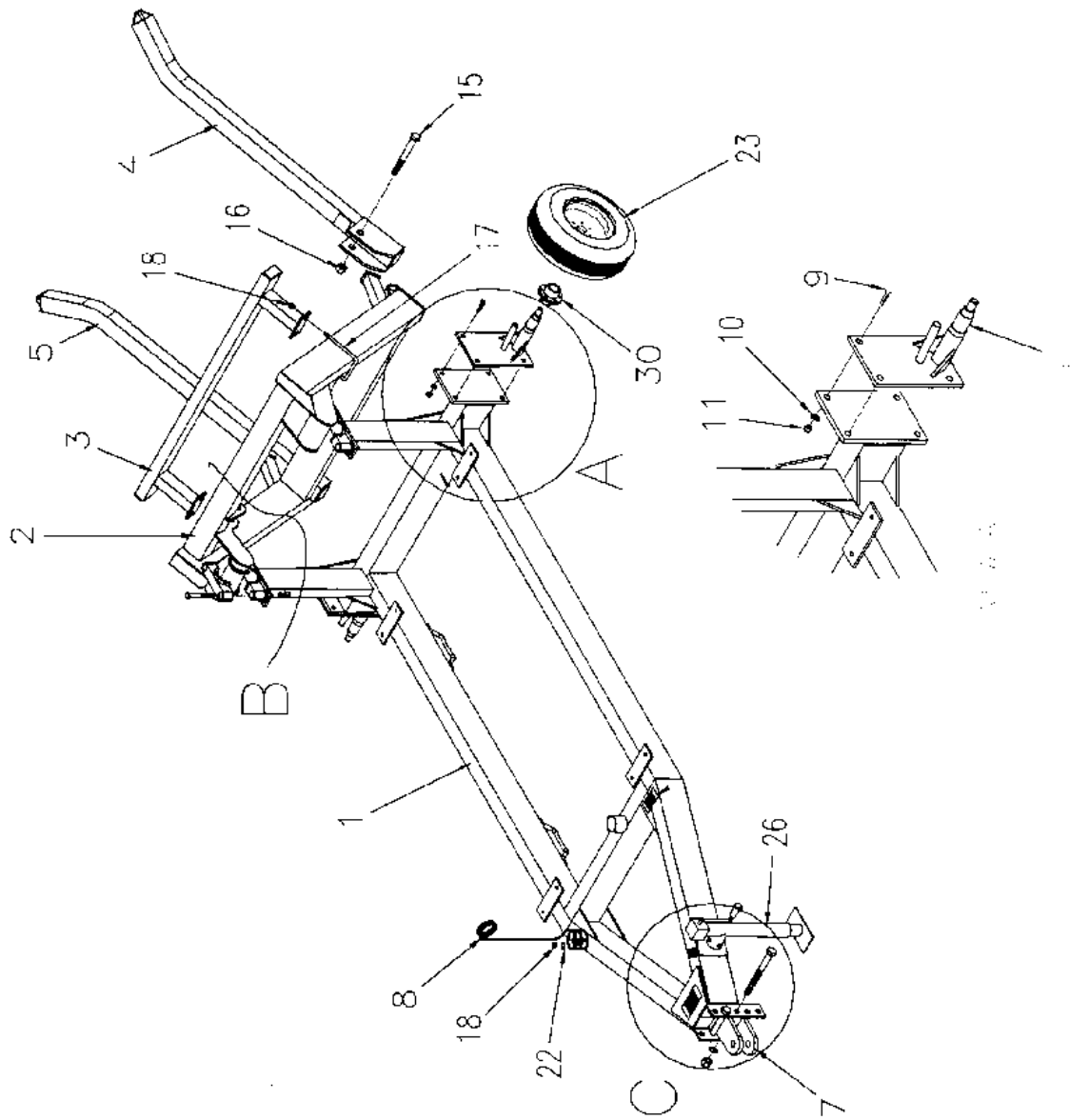

Item No.	Part No.	Description
1	49019	Frame
2	45192	Loading Assembly
3	45087	Bumper
4	45142	Left Fork
5	45143	Right Fork
6	49022	Axle Assembly
7	45060	Hitch Tongue
8	30206	Hydraulic Hose Holder
9	B5C1240P	3/4" x 2-1/2" UNC Gr. 5 Bolt
10	LW12P	3/4" Lock Washer
11	NC12P	3/4" UNC Nut
12	B5C16120P	1" x 7-1/2" UNC Gr. 5 Bolt
13	LW16P	1" Lock Washer
14	NC16P	1" UNC Nut
15	B5C2096P	1-1/4" x 6" UNC Gr. 5 Bolt
16	LNC20	1-1/4" Lock Nut
17	UB0848112	1/2" x 3" x 7" U Bolt
18	LNC08P	1/2" Lock Nut
19	B5C1072P	5/8" x 4-1/2" UNC Gr. 5 Bolt
20	FW10P	5/8" Flat Washer
21	LNC10P	5/8" Lock Nut
22	FW08P	1/2" Flat Washer
23	49021	Wheel Assembly (complete)
24	30230	Top Pipe Clamp
25	30231	Bottom Pipe Clamp
26	92095	5000 lb. Hitch Jack

Tub on Cart Installation

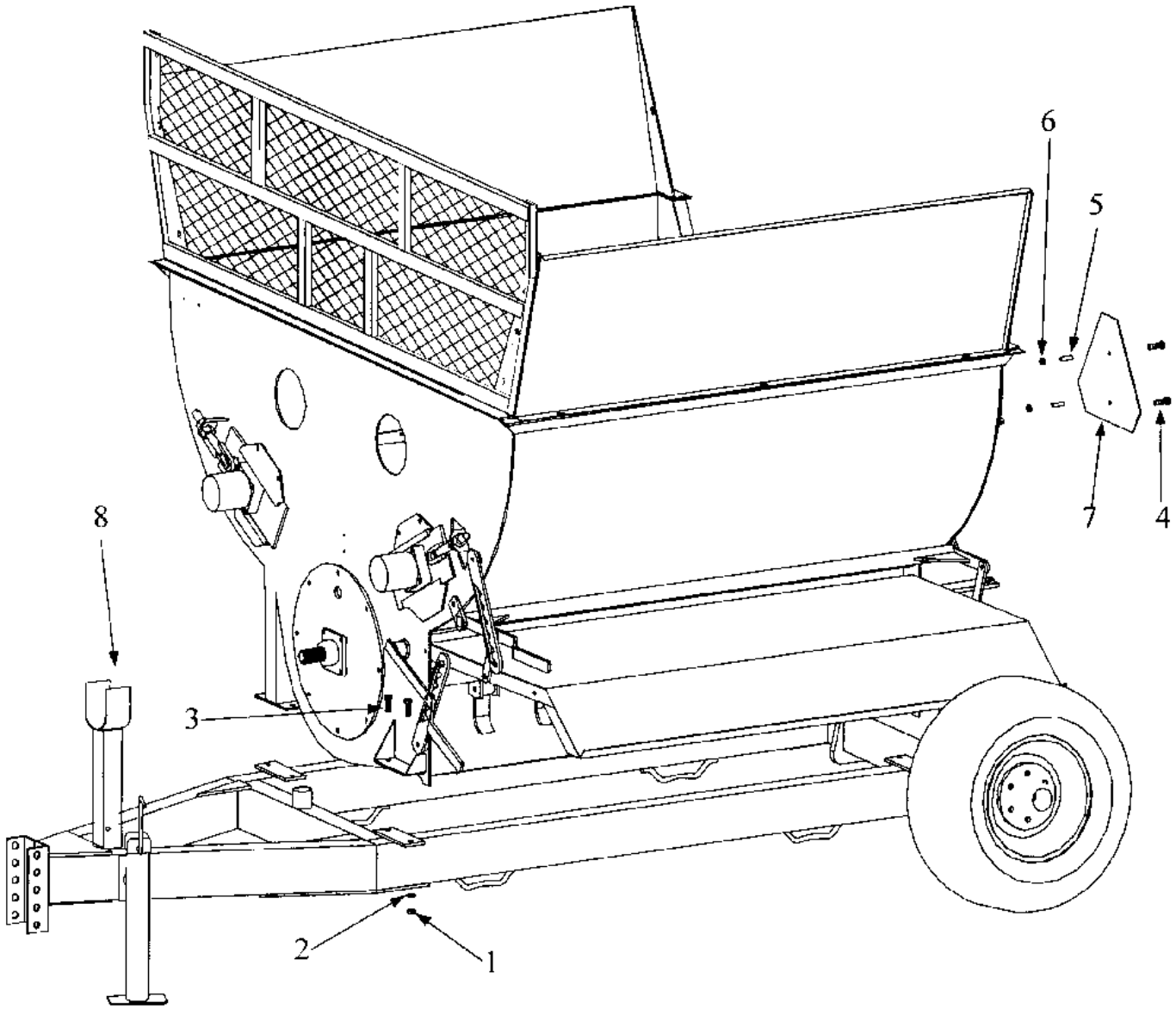

Item No.	Part No.	Description
1	LNC08P	1/2" UNC Lock Nut
2	FW08P	1/2" Flat Washer
3	B5C0824P	1/2" x 1-1/2" UNC Gr. 5 Bolt
4	B5C0432P	1/4"x 2" UNC Gr. 5 Bolt
5	E3254	Spacer Bushing
6	LNC04P	1/4" Lock Nut
7	92028	Slow Moving Sign
8	49020	CV Support

Cylinder Assembly

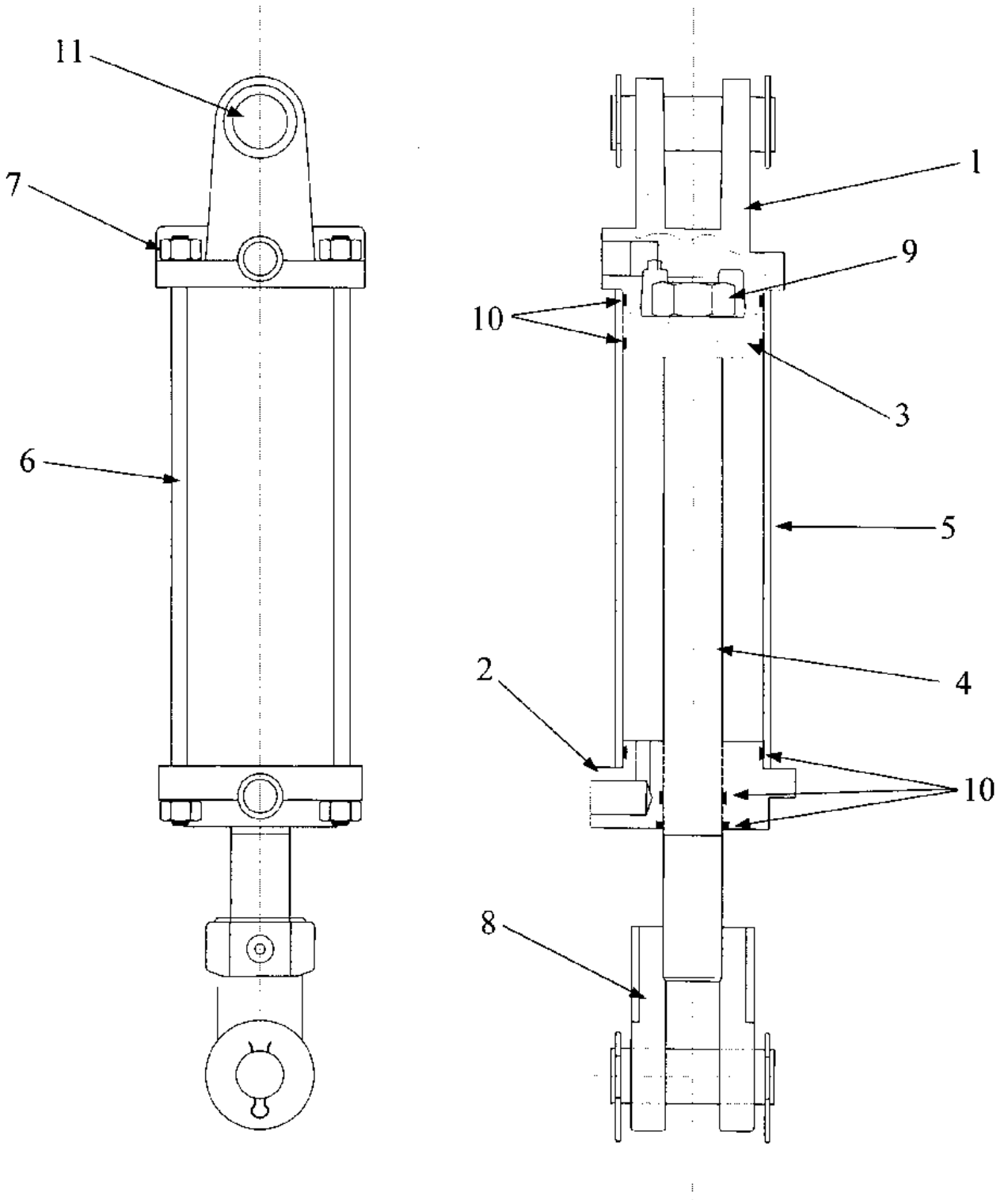

Item No.	Part No.	Description
1	90991	Clevis Cap
2	90992	Rod Cap
3	90706	Piston
4	90846	1-1/2" Rod
5	90993	Cylinder Tube
6	90994	1/2" Tie Rod
7	90800	1/2" UNF Nut
8	90849	Rod Clevis
9	90722	1-14 UNF Nut
10	90676	Seal Kit
11	45185	Top Cylinder Pin
	90133	3" x 16" - 1-1/2" Rod Cylinder

Hydraulic Layout

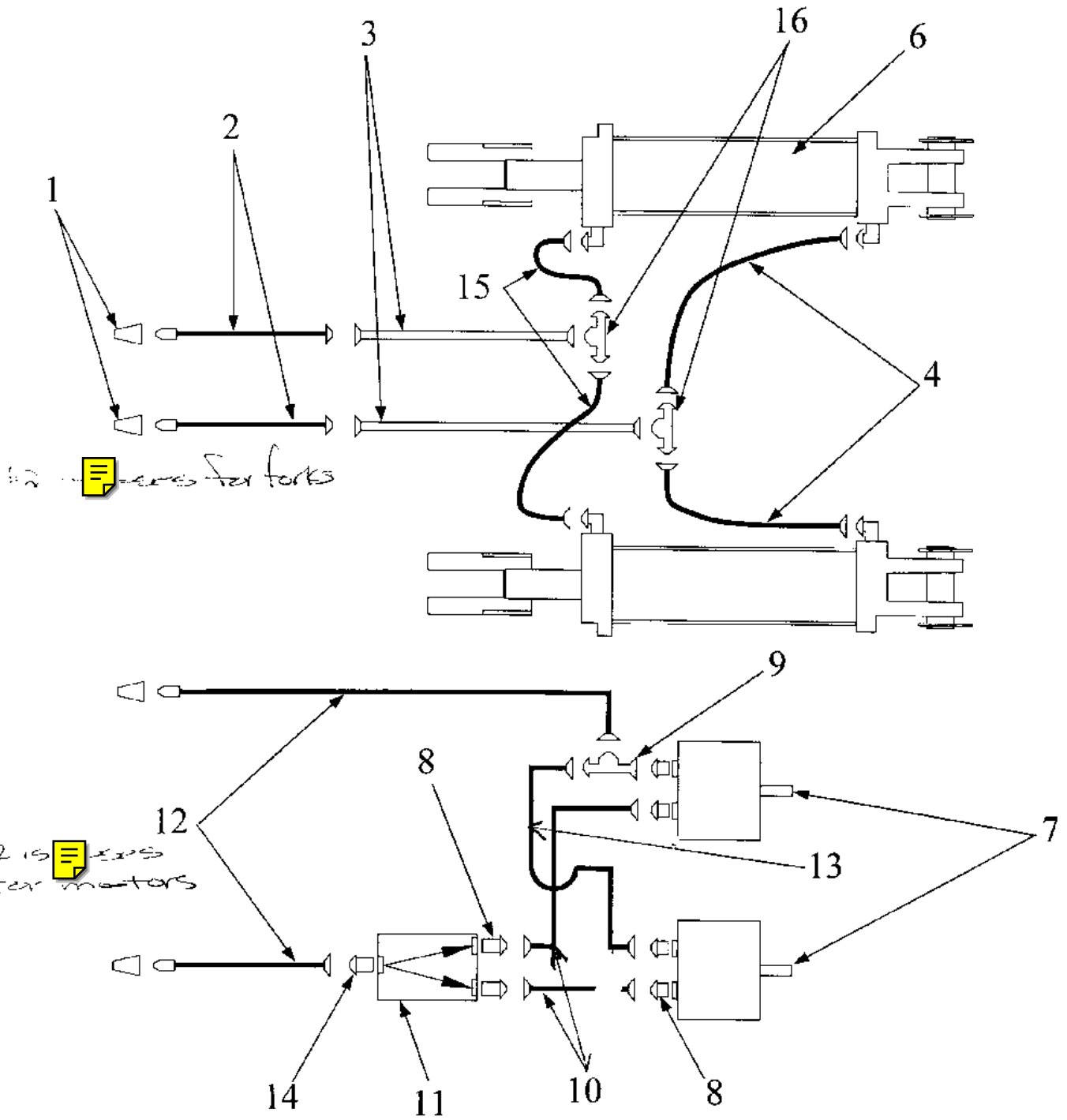

Item No.	Part No.	Description
1	30209	1/2" Pioneer End
2	30280	3/8" x 96" 8MP - 8MJX Hose
3	30275	1/2" Steel Line
4	90333	3/8" x 28" 8FJX Hose
5	30212	8MP - 8MJ90 Fitting
6	90133	3" x 16" - 1-1/2" Rod Hydraulic Cylinder
7	92145	Hydraulic Motor
8	30204	10MB - 8MJ Fitting
9	30150	8FJXR - 8MJT
10	90240	3/8" x 36" 8FJX Hose
11	45232	Flow Divider
12	30281	1/2" x 96" 8MP - 8FJX Hose
13	90271	3/8" x 42" 8FJX Hose
14	30145	10MBX - 8MJ90 Fitting
15	90332	3/8" x 20" 8FJX Hose
16	30313	8MJT Fitting

CV Assembly

Tractor End

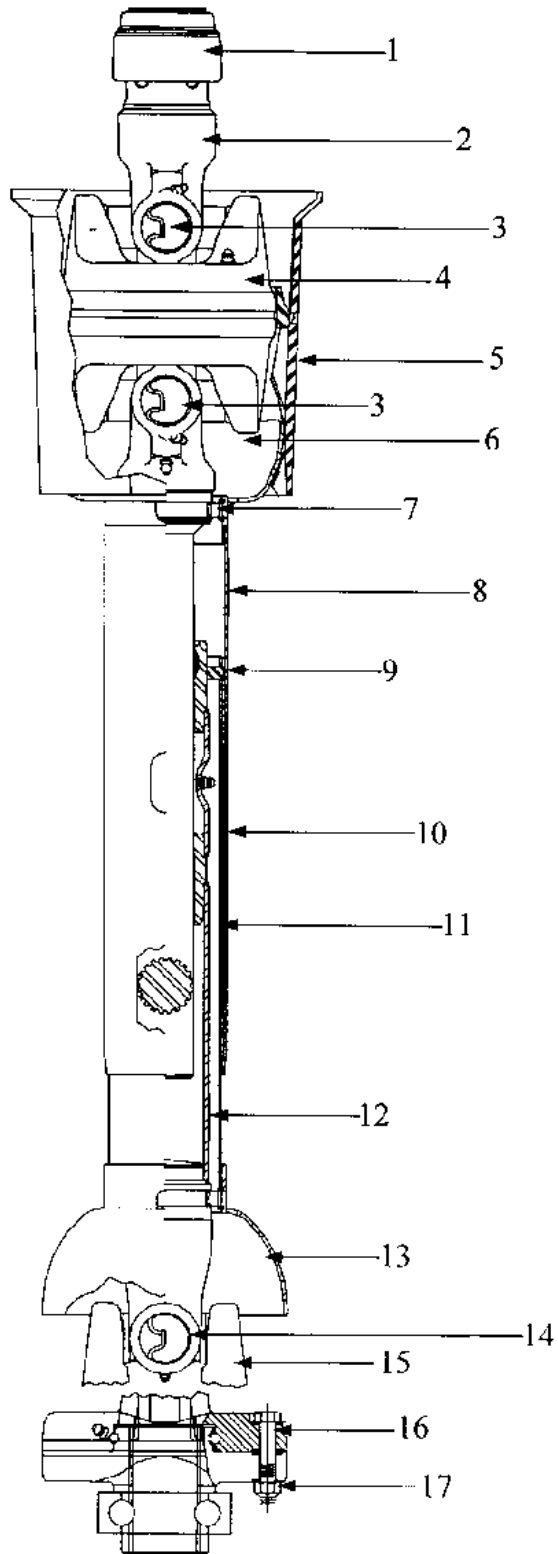

Item No.	Part No.	Description
1	30352	Auto Lock Repair Kit
2	30353	Auto Lock Yoke Assembly
3	30354	Cat 4 80 Degree Cross and Bearing
4	30355	Center Housing
5	30356	Bell Extension (With Centralizer)
6	30357	Yoke and Shaft
7	30358	Nylon Repair Kit
8	30359	Safety Sign
9	30360	Centralizer
10	30361	Outer Guard
11	30362	Inner Guard
12	30363	Safety Sign
13	30364	Yoke, Tube, and Slip Sleeve
14	30365	35R Cross and Bearing Kit
15	30366	Ball Shear Assembly
16	30367	3/8" x 2" - 16 Gr. 5 Bolt (Shear Bolt)
17	30368	3/8" - 16 Lock Nut

- bell is on this part.
includes

18 31685 1/4 - 20 screws
19 30449 540



7. Specifications

Recommend	
Minimum Horsepower required:	85 HP
Capacity:	2 bales - 6' long, 6' diameter or smaller
Flail Drum Length	70-1/4"
Flail Drum Diameter	20-5/8" Balanced
Flails	26 - 7/16" x 6-7/16" Tempered Spring Steel
Tires	2 - 11L x 15 Highway Service
Height:	105-1/2" (Fully Assembled)
Width	104-1/2"
Length	179"
Weight	4000 lb.
CV Requirements:	1000 R.P.M.
Dual Hydraulics	Dual Remote, 2000 psi
Cylinders	2 - 3" x 16", 1-1/2" Rod Diameter.